

NTD

NATIONAL TRACKED DUMPER HIRE LTD



3.5 TONNE SWIVEL

SPECIFICATION

All dimensions below were correct at time of print, E&OE.



MODEL: C50R-5 TV

4 CYLINDER, DISPLACEMENT: 3 LITRES

94PS / 83.2KW @ 2500RPM / EU Stage 5

FUEL TANK CAPACITY: 148 LITRES

BI-DIRECTIONAL SEAT POSITIONS

MACHINE WEIGHT: 6042KG • PAYLOAD: 3500KG

MAX TRAVEL SPEED: 9.2KPH

GRADEABILITY (EMPTY): 30°

GROUND PRESSURE (UNLOADED): 0.21KG/CM²

GROUND PRESSURE (LOADED): 0.33KG/CM²

TRACK WIDTH: 450MM • SLEW RADIUS: 2615MM

DUMP BODY CAPACITY (STRUCK): 1.2M³

DUMP BODY CAPACITY (HEAPED): 2.1M³

Equipped with a 180° slewing skip and rotating operators seat, allowing the operator a 3-sided tip operation and making this machine a versatile tool for material handling.

Having a closed air conditioned and heated operators cab with a swivel seat system allowing the option of a forward or rear tipping set up, this machine is a perfect choice for dusty sites and winter months. The C50R-5 TV is EU Stage 5 ready.

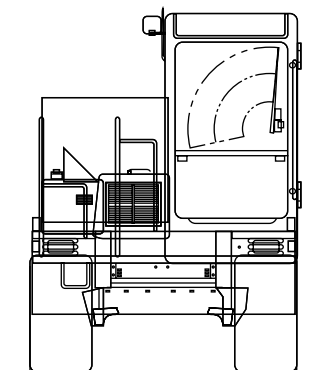

TOTAL WIDTH: 2200mm

TOTAL LENGTH: 4540mm

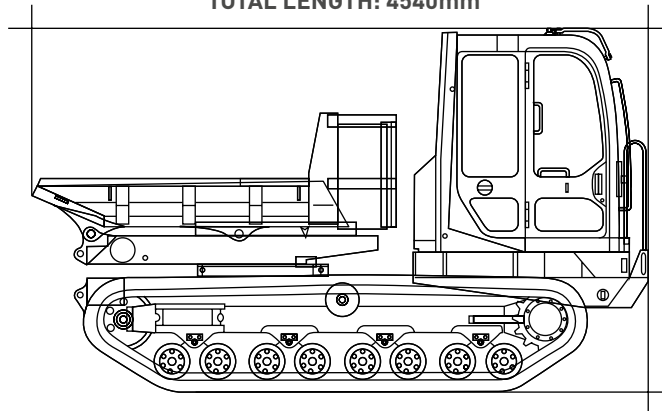

TOTAL HEIGHT: 2730mm

FEATURE ICONS



SEATBELT BEACON SYSTEM



ROPS OPERATORS CAB



BIODEGRADABLE HYDRAULIC OIL



HYDRAULIC ISOLATION SYSTEM



REVERSING CAMERA



360° CAMERA



360° SLEWING

NTD National Tracked Dumper Hire Ltd, Weston Yard, Albury, Surrey GU5 9AF

0844 376 0051

hiredesk@ntdh.co.uk

www.ntdh.co.uk

