

NTD

NATIONAL TRACKED DUMPER HIRE LTD



5.5 TONNE 360° SLEW

SPECIFICATION

All dimensions below were correct at time of print, E&OE.



MODEL: MST-1000VDR

4 CYLINDER, DISPLACEMENT: 4.4 LITRES

124PS / 82.6KW @ 2200RPM / EU Stage 4

FUEL TANK CAPACITY: 140 LITRES | ADBLUE 19 LITRES

MACHINE WEIGHT: 9140KG

PAYLOAD: 5500KG

MAX TRAVEL SPEED: 9.6KPH

GRADEABILITY (EMPTY): 15°

GROUND PRESSURE (UNLOADED): 0.27KG/CM² | 3.89 PSI

GROUND PRESSURE (LOADED): 0.43KG/CM² | 6.22 PSI

TRACK WIDTH: 700MM • SLEW RADIUS: 2820MM

DUMP BODY CAPACITY (STRUCK): 2.05M³

DUMP BODY CAPACITY (HEAPED): 3.5M³

These small to mid-range 360° slewing tracked dumpers are a very popular model. This machine can fully tip a load at any radius, particularly useful on riverbanks where the operator may not have space to turn or where turning and reversing may be a risk. This offers huge safety and environmental benefits. The operator is kept in a face forward position at all times, resulting in faster speed of operation with comfort, there is almost never a need to reverse this machine. This model is Tier 4 Final/Stage 4.

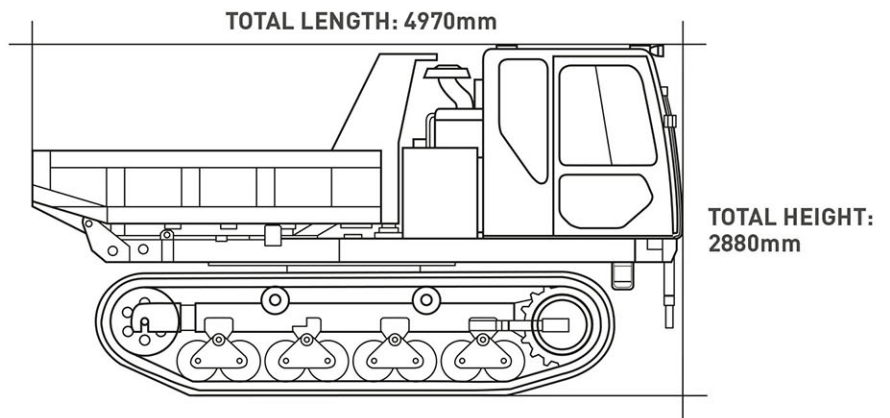
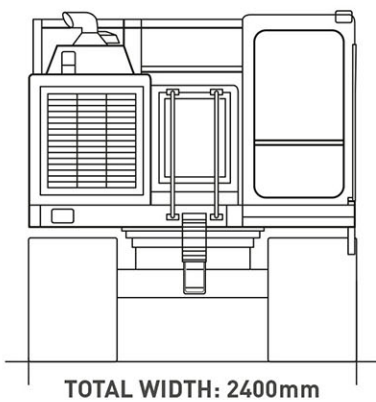

FEATURE ICONS



SEATBELT BEACON SYSTEM



ROPS OPERATORS CAB



BIODEGRADABLE HYDRAULIC OIL



HYDRAULIC ISOLATION SYSTEM



REVERSING CAMERA



360° CAMERA



360° SLEWING

NTD National Tracked Dumper Hire Ltd, Weston Yard, Albury, Surrey GU5 9AF

0844 376 0051

hiredesk@ntdh.co.uk

www.ntdh.co.uk

