

NTD

NATIONAL TRACKED DUMPER HIRE LTD



2.5 TONNE SWIVEL

SPECIFICATION

All dimensions below were correct at time of print, E&OE.



MODEL: MST-300VDR

4 CYLINDER, DISPLACEMENT: 2.2 LITRES

47PS / 35.4KW @ 2800RPM / EU Stage IIIB

FUEL TANK CAPACITY: 61 LITRES

BI-DIRECTIONAL SEAT POSITIONS

MACHINE WEIGHT: 2710KG • PAYLOAD: 2500KG

MAX TRAVEL SPEED: 9KPH

GRADEABILITY (EMPTY): 30°

GROUND PRESSURE (UNLOADED): 0.30KG/CM²

GROUND PRESSURE (LOADED): 0.57KG/CM²

TRACK WIDTH: 350MM • SLEW RADIUS: 1600MM

DUMP BODY CAPACITY (STRUCK): 0.88M³

DUMP BODY CAPACITY (HEAPED): 1.58M³

Equipped with a 160° slewing skip, the MST-300 VDR allows the operator to side tip from both forward tipping and rear tipping set up. The engine complies with EU Interim Tier 4i emissions and EU Stage 111B.

A Bi-Directional seat system that dramatically reduces the amount of turning and reversing. This machine is a great choice for projects of any size with restricted space.

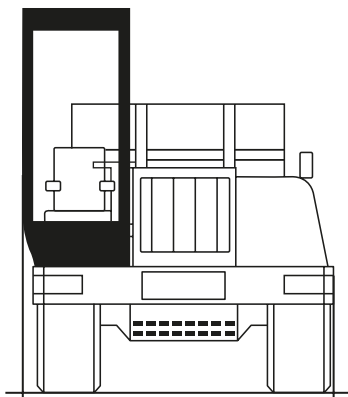

TOTAL WIDTH: 1745mm

TOTAL HEIGHT:
2330mm

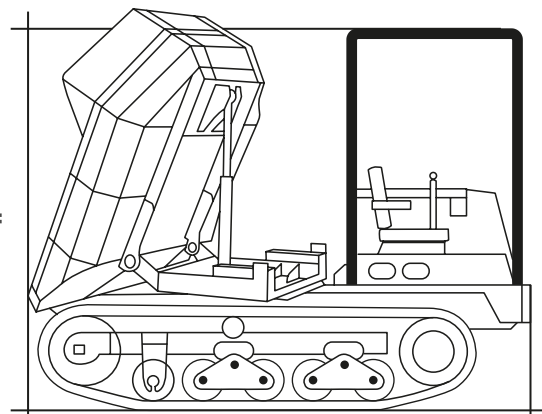

TOTAL LENGTH: 3490mm

FEATURE ICONS



SEATBELT BEACON SYSTEM



ROPS OPERATORS CAB



BIODEGRADABLE HYDRAULIC OIL



HYDRAULIC ISOLATION SYSTEM



REVERSING CAMERA



360° CAMERA



360° SLEWING

NTD National Tracked Dumper Hire Ltd, Weston Yard, Albury, Surrey GU5 9AF

0844 376 0051

hiredesk@ntdh.co.uk

www.ntdh.co.uk

