

# NTD

NATIONAL TRACKED DUMPER HIRE LTD



## 5 TONNE RIGID

## SPECIFICATION

All dimensions below were correct at time of print, E&OE.



### MODEL: MST-800VD (up to 2017)

4 CYLINDER, DISPLACEMENT: 4.4 LITRES

131PS / 96.5KW @ 2200RPM / EU Stage IIIA

FUEL TANK CAPACITY: 130 LITRES

MACHINE WEIGHT: 6500KG

PAYLOAD: 4800KG

MAX TRAVEL SPEED: 11KPH

GRADEABILITY (EMPTY): 30°

GROUND PRESSURE (UNLOADED): 0.22KG/CM<sup>2</sup>

GROUND PRESSURE (LOADED): 0.38KG/CM<sup>2</sup>

TRACK WIDTH: 600MM

DUMP BODY CAPACITY (STRUCK): 1.77M<sup>3</sup>

DUMP BODY CAPACITY (HEAPED): 2.9M<sup>3</sup>

Flat body and drop down sides makes this machine a great carrier tool as well as a tip body dumper. Low ground pressure and great payload ability combined with a large fuel tank and good tracking speeds make this mid-sized tracked dumper a popular choice for many sites. **Optional towing hitch available.**

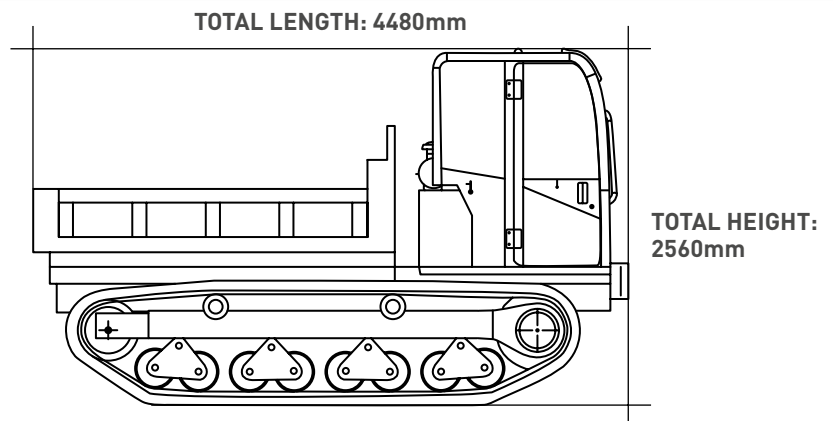
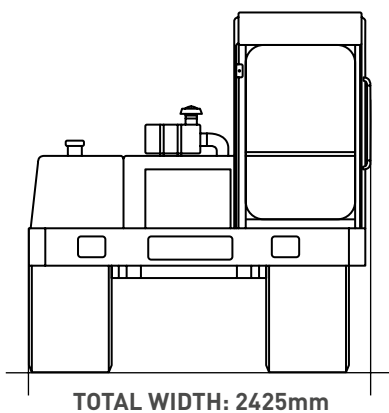

### FEATURE ICONS



SEATBELT BEACON SYSTEM



ROPS OPERATORS CAB



BIODEGRADABLE HYDRAULIC OIL



HYDRAULIC ISOLATION SYSTEM



REVERSING CAMERA



360° CAMERA



360° SLEWING

NTD National Tracked Dumper Hire Ltd, Weston Yard, Albury, Surrey GU5 9AF

0844 376 0051

hiredesk@ntdh.co.uk

www.ntdh.co.uk



# NTD

NATIONAL TRACKED DUMPER HIRE LTD



## 5 TONNE RIGID

## SPECIFICATION

All dimensions below were correct at time of print, E&OE.



### MODEL: MST-800VD (from 2018)

4 CYLINDER, DISPLACEMENT: 4.4 LITRES

124PS / 92.6KW @ 2200RPM / EU Stage IIIB

FUEL TANK CAPACITY: 130 LITRES

MACHINE WEIGHT: 7200KG

PAYLOAD: 5000KG

MAX TRAVEL SPEED: 11KPH

GRADEABILITY (EMPTY): 30°

GROUND PRESSURE (UNLOADED): 0.22KG/CM<sup>2</sup>

GROUND PRESSURE (LOADED): 0.38KG/CM<sup>2</sup>

TRACK WIDTH: 600MM

DUMP BODY CAPACITY (STRUCK): 1.77M<sup>3</sup>

DUMP BODY CAPACITY (HEAPED): 2.9M<sup>3</sup>



Flat body and drop down sides makes this machine a great carrier tool as well as a tip body dumper. Low ground pressure and great payload ability combined with a large fuel tank and good tracking speeds make this mid-sized tracked dumper a popular choice for many sites. **Optional towing hitch available.**

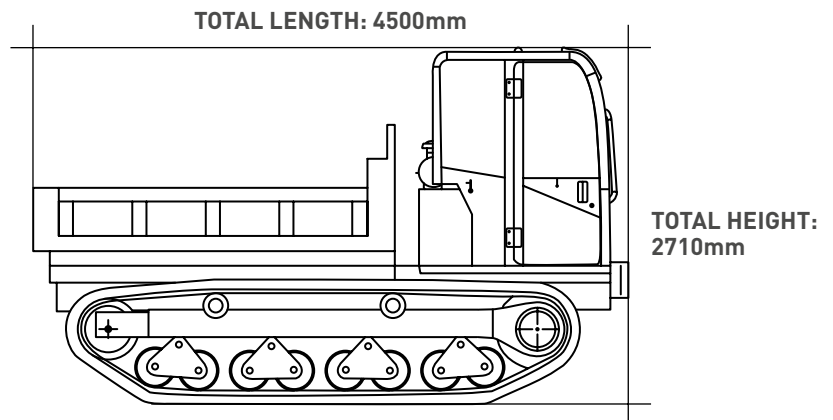
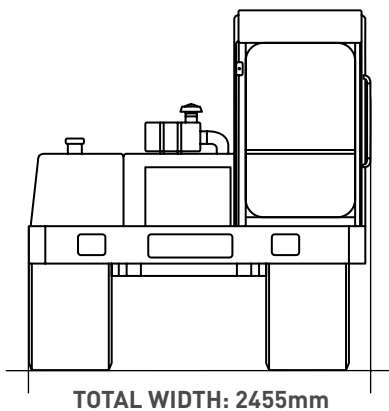

### FEATURE ICONS



SEATBELT BEACON SYSTEM



ROPS OPERATORS CAB



BIODEGRADABLE HYDRAULIC OIL



HYDRAULIC ISOLATION SYSTEM



REVERSING CAMERA



360° CAMERA



360° SLEWING

NTD National Tracked Dumper Hire Ltd, Weston Yard, Albury, Surrey GU5 9AF

0844 376 0051

hiredesk@ntdh.co.uk

www.ntdh.co.uk

