

# NTD

NATIONAL TRACKED DUMPER HIRE LTD

## 15 TONNE 360° SLEW

## SPECIFICATION

All dimensions below were correct at time of print, E&OE.



### MODEL: MST-3000VDR

CAT C7.1 ACERT: 7.1 LITRES

253PS / 186KW @ 2200RPM / EU Stage 5

FUEL TANK CAPACITY: 300 LITRES (AD BLUE: 27 LITRES)

MACHINE WEIGHT: 16800KG

PAYLOAD: 15000KG

MAX TRAVEL SPEED: 12.07KPH

GROUND PRESSURE (UNLOADED): 3.6 PSI

GROUND PRESSURE (LOADED): 8 PSI

TRACK WIDTH: 800MM • SLEW RADIUS: 3200MM

DUMP BODY CAPACITY (STRUCK): 4.35M<sup>3</sup>

DUMP BODY CAPACITY (HEAPED): 6.8M<sup>3</sup>

The Morooka MST 3000VDR is one of our largest tracked dumpers with an impressive 15000 kg payload. This machine is a real workhorse with a rotatable dump bed for precision work. The upper structure rotates a full 360°, so you can deliver your load where you need it and return without spinning the undercarriage.

The MST3000VDR is powered by a CAT® C7.1 engine and features a heated and air-conditioned ROPS certified cabin, back-up camera, video information display, remote mirror and easy to use joystick control. Tailgate option is available with the MST-3000VDR machine.

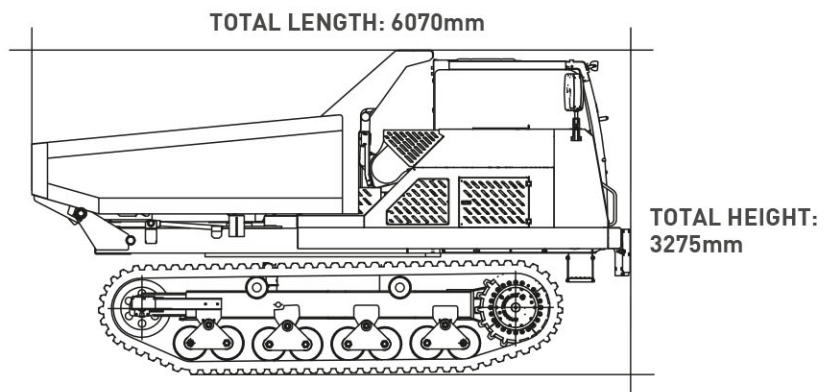
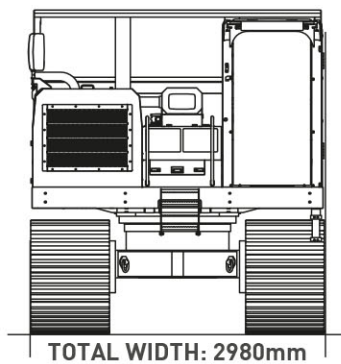

### FEATURE ICONS



HUMAN FORM RECOGNITION SYSTEM



ROPS OPERATORS CAB



BIODEGRADABLE HYDRAULIC OIL



HYDRAULIC ISOLATION SYSTEM



SEATBELT BEACON SYSTEM



REVERSING CAMERA



360° CAMERA



360° SLEWING

NTD National Tracked Dumper Hire Ltd, Weston Yard, Albury, Surrey GU5 9AF

0844 376 0051

hiredesk@ntdh.co.uk

www.ntdh.co.uk

