

# NTD

NATIONAL TRACKED DUMPER HIRE LTD



## 13.2 TONNE 360° SLEW

## SPECIFICATION

All dimensions below were correct at time of print, E&OE.



### MODEL: PANTHER T14R

6 CYLINDER, DISPLACEMENT: 7.1 LITRES

253PS / 186KW @ 2200RPM / EU Stage 4

FUEL TANK CAPACITY: 300 LITRES

MACHINE WEIGHT: 16860KG

PAYLOAD: 13200KG

MAX TRAVEL SPEED: 13KPH

GRADEABILITY (EMPTY): 30°

GROUND PRESSURE (UNLOADED): 0.36KG/CM<sup>2</sup>

GROUND PRESSURE (LOADED): 0.59KG/CM<sup>2</sup>

TRACK WIDTH: 750MM • SLEW RADIUS: 3200MM

DUMP BODY CAPACITY (STRUCK): 5.8M<sup>3</sup>

DUMP BODY CAPACITY (HEAPED): 6.6M<sup>3</sup>

This impressive sized tracked dumper offers the highest speed combined with the highest payload in its class and will set new standards for productivity and mobility. With its 13,200 kg capacity, this rubber tracked crawler carrier has the largest payload of any vehicle of this type in its category.

The rotating separation of this vehicle allows the operator to work in tight, sensitive areas where other vehicles do not have access. Together with a ground pressure of 7.46 psi and a strong pull ratio, these features allow this carrier crawler to be suitable for all major muck shifting, pipeline and most variations of projects, especially if the terrain is difficult, without damage to the environment.

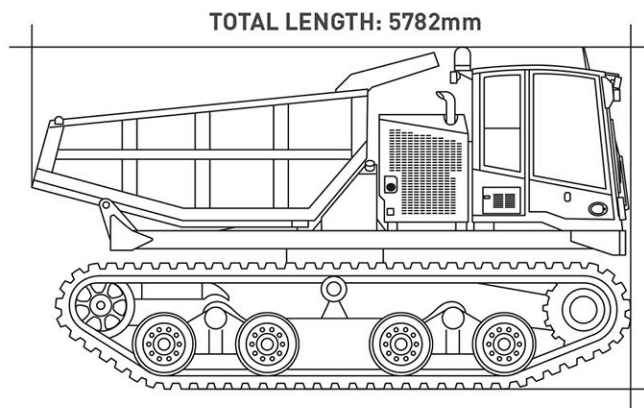
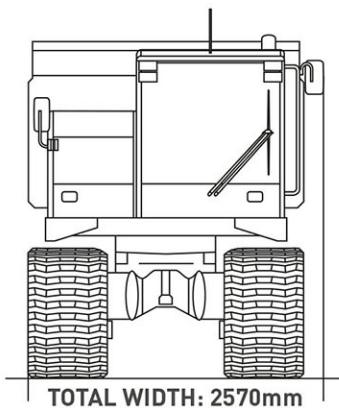

TOTAL HEIGHT: 3214mm

### FEATURE ICONS



SEATBELT BEACON SYSTEM



ROPS OPERATORS CAB



BIODEGRADABLE HYDRAULIC OIL



HYDRAULIC ISOLATION SYSTEM



REVERSING CAMERA



360° CAMERA



360° SLEWING

NTD National Tracked Dumper Hire Ltd, Weston Yard, Albury, Surrey GU5 9AF

0844 376 0051

hiredesk@ntdh.co.uk

www.ntdh.co.uk

