

# NTD

NATIONAL TRACKED DUMPER HIRE LTD



## 6 TONNE SWIVEL

## SPECIFICATION

All dimensions below were correct at time of print, E&OE.



The Dual View 4-T is a powerful addition to our mid-sized range of tracked dumpers and comes equipped with a payload ability of 6 tonne. Its innovative Dual View system allows the driver to turn the seat and console 180° to guarantee unrestricted visibility and ensure maximum safety at all times. The unique Four-Track system is designed for difficult terrains and sensitive surface conditions, minimising impact on the environment. A great alternative to 4 wheeled loaders and 2 tracked carriers. The DV60 offers high levels of operational efficiency, economy and environmental compliance.

### MODEL: DV60

4 CYLINDER, DISPLACEMENT: 2.9 LITRES

74PS / 55.4KW @ 2300RPM / EU Stage IIIB

FUEL TANK CAPACITY: 80 LITRES

MACHINE WEIGHT: 6930KG

PAYLOAD: 6000KG

MAX TRAVEL SPEED: 16KPH

GRADEABILITY (EMPTY): 30°

GROUND PRESSURE (UNLOADED): 0.30KG/CM<sup>2</sup>

GROUND PRESSURE (LOADED): 0.57KG/CM<sup>2</sup>

TRACK WIDTH: 495MM

DUMP BODY CAPACITY (STRUCK): 2.35M<sup>3</sup>

DUMP BODY CAPACITY (HEAPED): 3.15M<sup>3</sup>

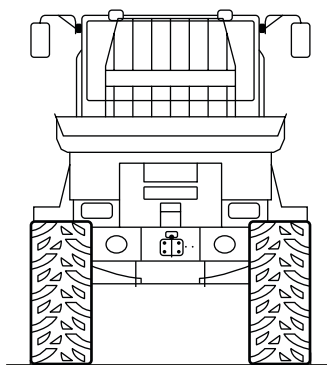

TOTAL WIDTH: 2350mm

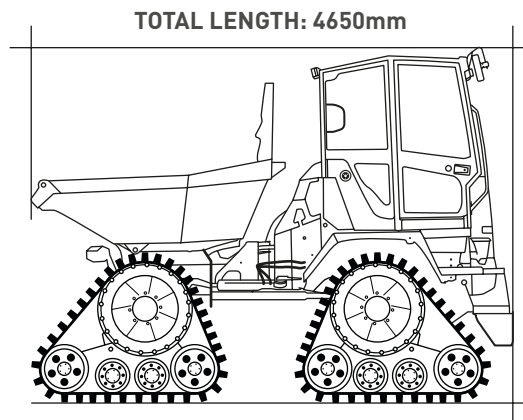

TOTAL LENGTH: 4650mm

TOTAL HEIGHT: 3250mm

### FEATURE ICONS



SEATBELT BEACON SYSTEM



ROPS OPERATORS CAB



BIODEGRADABLE HYDRAULIC OIL



HYDRAULIC ISOLATION SYSTEM



REVERSING CAMERA



360° CAMERA



360° SLEWING

NTD National Tracked Dumper Hire Ltd, Weston Yard, Albury, Surrey GU5 9AF

0844 376 0051

hiredesk@ntdh.co.uk

www.ntdh.co.uk

