

NTD

NATIONAL TRACKED DUMPER HIRE LTD

11 TONNE 360° SLEW

SPECIFICATION

All dimensions below were correct at time of print, E&OE.



MODEL: MST-110CR

6 CYLINDER, DISPLACEMENT: 7.1 LITRES

253PS / 186KW @ 2200RPM / EU Stage 4 and 5

FUEL TANK CAPACITY: 300 LITRES (AD BLUE: 27 LITRES)

MACHINE WEIGHT: 16000KG

PAYLOAD: 11000KG

MAX TRAVEL SPEED: 10KPH

GROUND PRESSURE (UNLOADED): 5.1 PSI

GROUND PRESSURE (LOADED): 8.7 PSI

TRACK WIDTH: 800MM • SLEW RADIUS: 3373MM

DUMP BODY CAPACITY (STRUCK): 3.97M³

DUMP BODY CAPACITY (HEAPED): 6.52M³

With a 360° rotation, this tracked dumper can fully tip a load at any radius. Useful on sites requiring a large volume carrying capacity where there are restrictions, such as confined routes, tunnels and riverbanks. Where turning and reversing may be a risk for the operator, this offers huge safety and environmental benefits.

The operator is kept in a face-forwarding position at all times, resulting in faster speed of operation with comfort. There is almost never a need to reverse this machine.

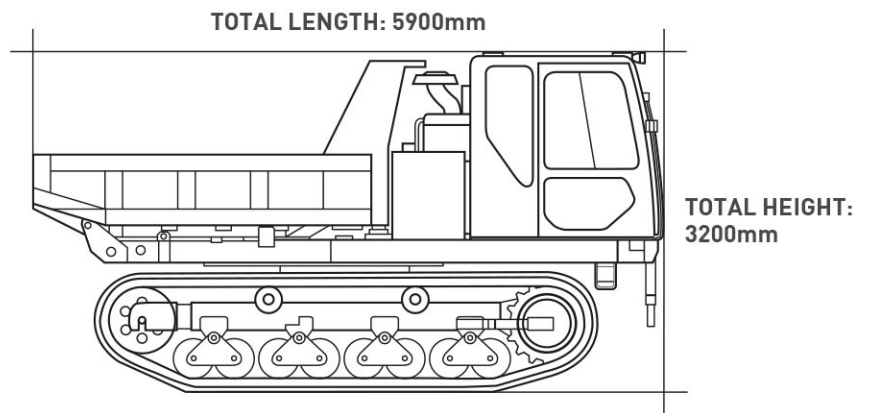
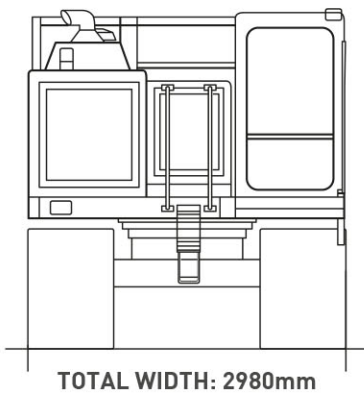

FEATURE ICONS



HUMAN FORM RECOGNITION SYSTEM



ROPS OPERATORS CAB



BIODEGRADABLE HYDRAULIC OIL



HYDRAULIC ISOLATION SYSTEM



SEATBELT BEACON SYSTEM



REVERSING CAMERA



360° CAMERA



360° SLEWING

NTD National Tracked Dumper Hire Ltd, Weston Yard, Albury, Surrey GU5 9AF

0844 376 0051

hiredesk@ntdh.co.uk

www.ntdh.co.uk

