

NTD

NATIONAL TRACKED DUMPER HIRE LTD

11 TONNE RIGID

SPECIFICATION

All dimensions below were correct at time of print, E&OE.



MODEL: MST-2200VD

6 CYLINDER, DISPLACEMENT: 7.242 LITRES

253PS / 186KW @ 2200RPM / EU Stage 4 and 5

FUEL TANK CAPACITY: 300 LITRES (AD BLUE: 27 LITRES)

MACHINE WEIGHT: 14100KG

PAYLOAD: 11000KG

MAX TRAVEL SPEED: 10KPH

GROUND PRESSURE (UNLOADED): 4.6 PSI

GROUND PRESSURE (LOADED): 8.5 PSI

TRACK WIDTH: 750MM

DUMP BODY CAPACITY (STRUCK): 3.53M³

DUMP BODY CAPACITY (HEAPED): 5.97M³

If you require a tracked dumper capable of carrying a larger volume for bulk material handling. This machine offers a carrying capacity of 11 tonne and is a popular selection on larger sites working in tandem with other machines to ensure high levels of productivity. This model is Tier 4 Final/Stage 4.

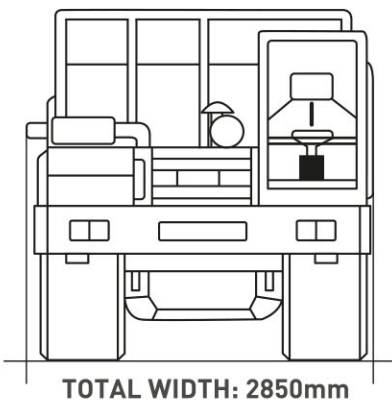

TOTAL WIDTH: 2850mm

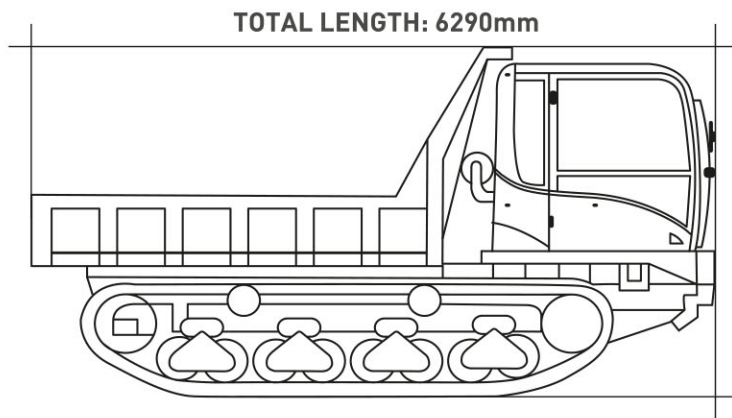

TOTAL LENGTH: 6290mm

TOTAL HEIGHT: 3170mm

FEATURE ICONS



HUMAN FORM RECOGNITION SYSTEM



ROPS OPERATORS CAB



BIODEGRADABLE HYDRAULIC OIL



HYDRAULIC ISOLATION SYSTEM



SEATBELT BEACON SYSTEM



REVERSING CAMERA



360° CAMERA



360° SLEWING

NTD National Tracked Dumper Hire Ltd, Weston Yard, Albury, Surrey GU5 9AF

0844 376 0051

hiredesk@ntdh.co.uk

www.ntdh.co.uk

